

GODIAG GT107 Gearbox Data Adapter ECU IMMO Kit

for PCMFlash PCMTuner KESSV2 for DQ200 DQ250 VL381 VL300 DQ500 DL501

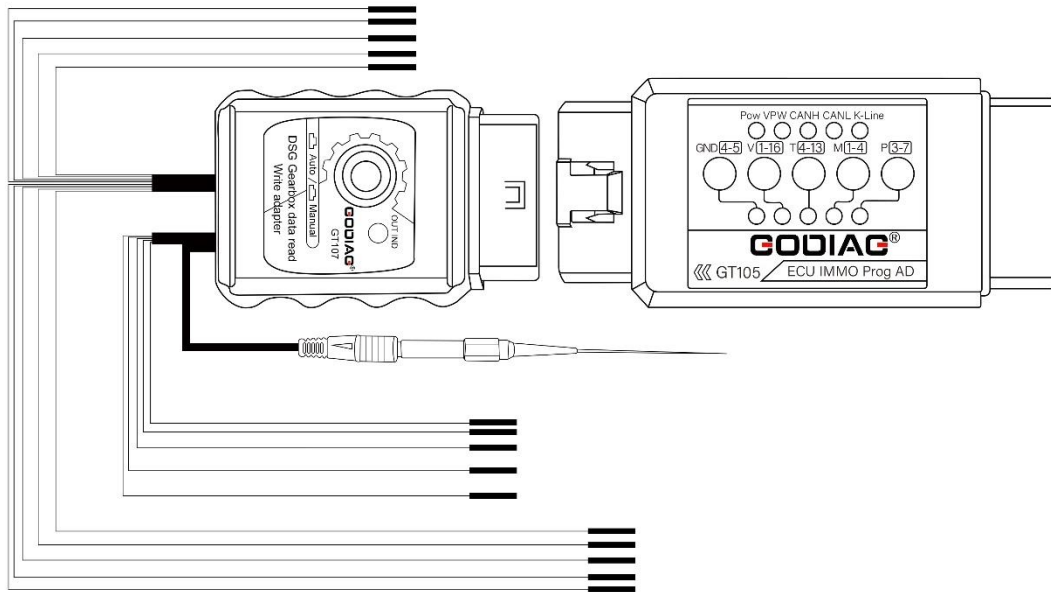

User's Manual v2.0

Please review the following statement carefully:

The statement can help you quickly learn how to use GODIAG products. Please abide by the relevant local laws. If you use the GODIAG equipment illegally, the user shall bear all the risks, and the company will not assume any responsibility.

For the safety of yourself and others, and to avoid damage to equipment and vehicles, please read the safety precautions carefully. Due to the variety of procedures, tools, parts and techniques used in vehicle maintenance, the variability in how personnel operate, and the variety of diagnostic programming applications, this manual cannot predict and provide safety recommendations for every situation.

It is the responsibility of the automotive service technician to get a thorough understanding of the system being tested and to use appropriate service methods and testing procedures reasonably.

When testing, you must use appropriate operating methods to avoid threats to yourself and others in the work area, as well as to avoid damage to the equipment being used or the vehicle being tested.

Before using the equipment, please refer to and follow the safety information and applicable test procedures provided by the vehicle or equipment manufacturer. Please use the equipment in accordance with the instructions in this manual, and read, understand and follow all safety information and instructions in the manual.

Note for reading and writing ECU data:

1. Connect the DSG gearbox in the studio to read and write data, be sure to use a stable and reliable power supply (12V 4A-5A). Note: Insufficient power supply can cause ECU damage or data loss.
2. If the car battery is connected as the power supply, it must be ensured that the voltage is at 12V and there is enough power in the vehicle battery (to support power for at least 30 minutes). It is recommended that you can start the car first and then connect the device. Note: Insufficient power supply can cause ECU damage or data loss.
3. Connect the power supply of Godiag ECU IMMO Prog AD first, and check that the IMMO function switch on it must be up (the switch is off)
4. View the DSG gearbox wiring definition and connect the DSG gearbox. Then connect GT107 to Godiag ECU IMMO Prog AD.
5. The "Auto" mode and "Manual" mode selection of the GT107 start switch is selected according to how you want to operate (the switch is popped up to be "Auto", and the switch is pressed down to be "Manual" . The "Manual" mode is used for PCMFlash software diagnosis. It is recommended to use the "Auto" mode for reading and writing data. Other software uses "Manual" mode.)
6. Since some ECU operations require special attention, please read the following content carefully.

GODIAG GT107 is a DSG gearbox connection adapter. DSG Gearbox maintenance engineers can clone, diagnose and repair DSG Gearbox ECU and can also read, write and adjust data or power for DSG Gearbox ECU via PCMFlash, PCMTuner, and Kessv2, etc.

This adapter has automatic and manual selection for PCMFlash software. For data reading and writing, you can choose "Auto", and for diagnosis you can choose "Manual". For ECU models DQ200, DQ250, DQ500 you can also choose "Manual". For other software like kessv2, please press down the 120 ohm resistor switch.

Moreover, with the car battery power, the adapter can directly read and write DSG Gearbox data and you can clearly check the communication status during the data reading and writing process.

GODIAG GT107 DSG Gearbox Data Adapter Support the

Connection of:

Renault DC0/DC4 Gen2

Honda LUK UDCT

DQ200 (0AM) [WR/CK]

DQ250C (02E) [RD/WR/CK]

DQ250E/F (02E) [WR/CK]

DQ200MQB/G2 (0CW) [WR/CK]

DQ250MQB (0D9) [WR/CK]

VL300/V30 (01J/0AN) [WR/CK]

VL381 (0AW) [WR/CK]

DL501/G2 (0B5) [WR/CK]

DQ500 (0BH/0BT) [RD/WR/CK] reading when using a direct connection.

DQ200/MQB/G2 Boot (MICRO) [RD/WR/CK]

DQ200/MQB/G2 Boot (EEPROM) [RD/WR]

DQ250E/F/MQB Boot (MICRO) [RD/WR/CK]

DQ250E/F/MQB Boot (EEPROM) [RD/WR]

VL300/V30 BSL (FLASH) [RD/WR/CK]

VL300/V30 BSL (EEPROM) [RD/WR/CK]

VL381 Boot (MICRO) [RD/WR/CK]

VL381 Boot (EEPROM) [RD/WR]

DL501/G2 Boot (MICRO) [RD/WR/CK]

DL501/G2 Boot (EEPROM) [RD/WR]

Maintenance workshop connection diagram:

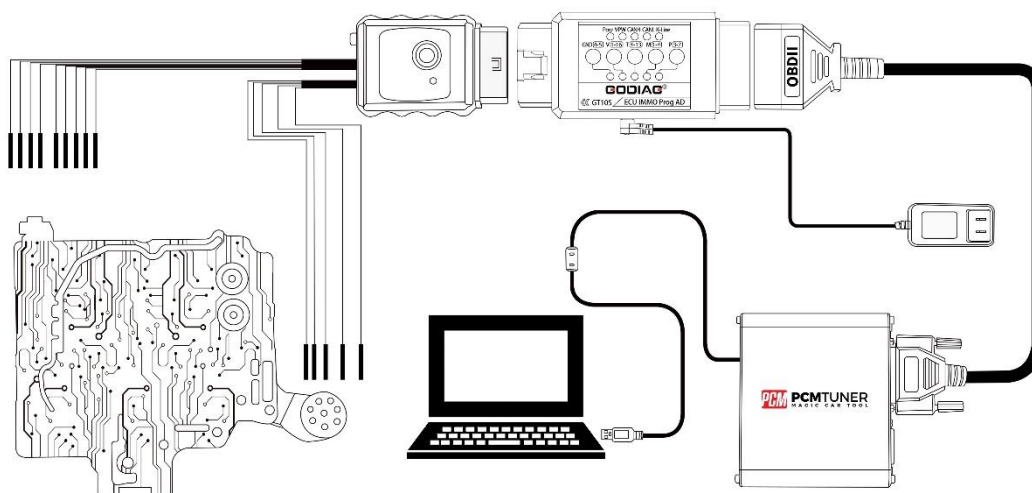

Connection Steps:

1. Connect Godiag GT107 to the gearbox ECU like VAG, DQ250, DQ200, VL381, VL300, DQ500, DL501, for Renault DC0/DC4 Gen2 and Honda LUK UDCT.
2. Connect GT105 and connect 12V 2A DC power supply. (GT105 IMMO function keys must be up.)
3. The GODIAG GT107 analog ignition switch is in “Auto” mode if it is not pressed, and in “Manual” mode if pressed down(note: please select the corresponding mode in the software to read data)
4. Connect PCMFlash, PCMTuner J2534passthru.
5. Perform data reading and writing operations.

Direct Car Connection Diagram

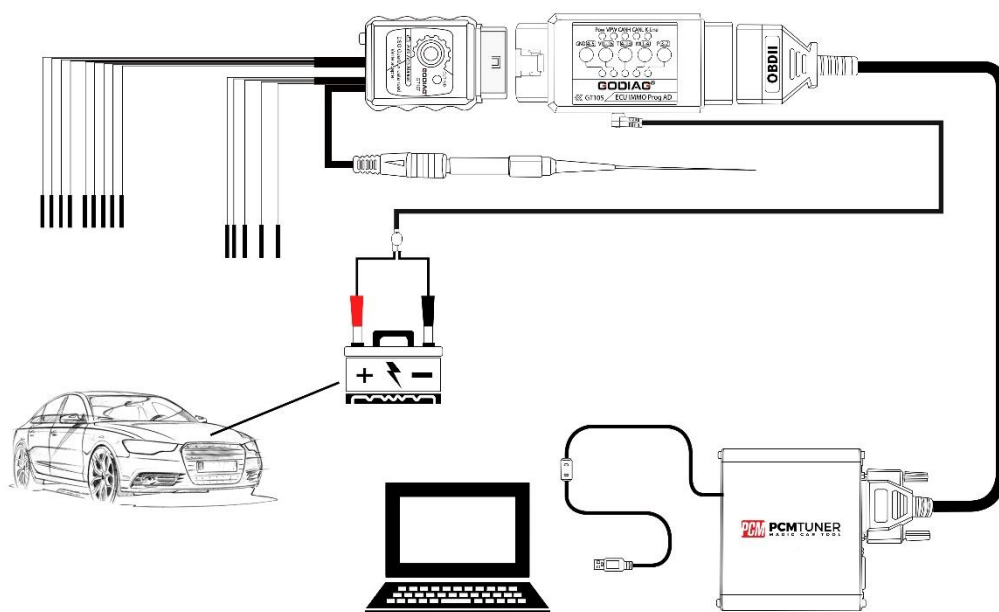

Steps:

1. Connect Godiag GT107 to the gearbox ECU, VAG, DQ250, DQ200, VL381, VL300, DQ500, DL501 for Renault DC0/DC4 Gen2 and Honda LUK UDCT.
2. Connect the Godiag ECU IMMO Prog AD and connect the 12V vehicle battery.(The Godiag ECU IMMO Prog AD's IMMO button must be up.)
3. The Godiag GT107 analog ignition switch is in “Auto” mode if it is not pressed, and it is in “Manual” mode if it is pressed down(Note: Please select the corresponding mode in the software for data reading).
4. Connect PCMFlash, PCMTuner J2534passthru.
5. Perform data reading and writing operations.

Gearbox ECU interface connection definition:

DQ200(0AM,0CW)

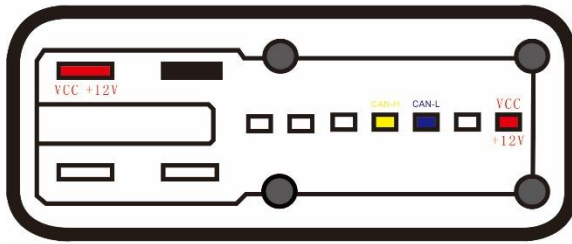

DQ 250 (02E,0D9)

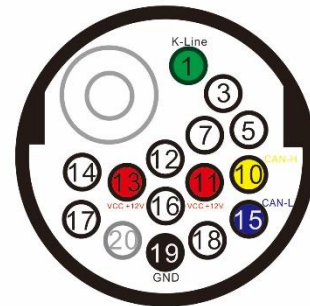

VL381(0AW)

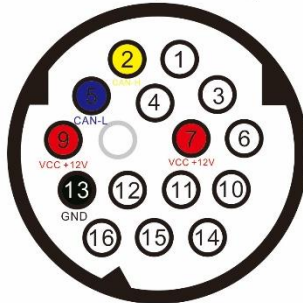

DQ500(0BT,0BH)
DQ380 DQ381

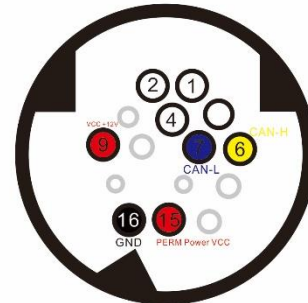

V30 (01J)

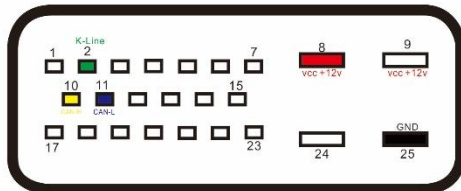

VL 300 (01J)

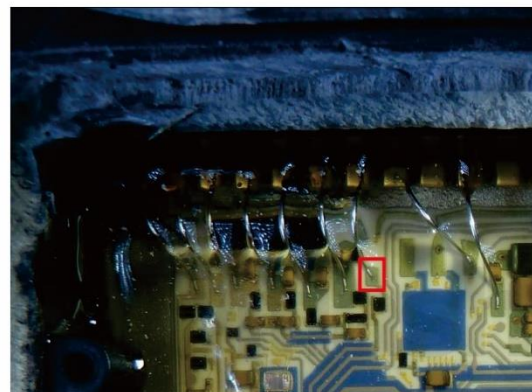
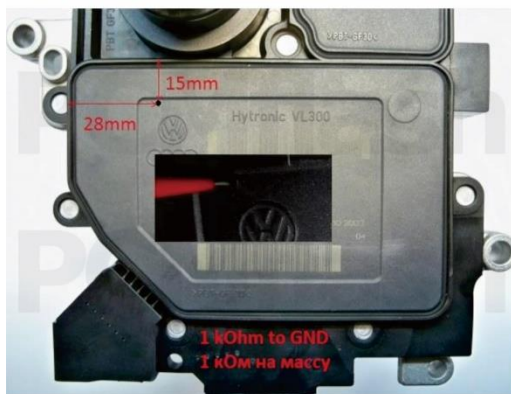
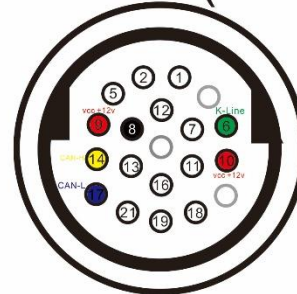

DL382(0CK)

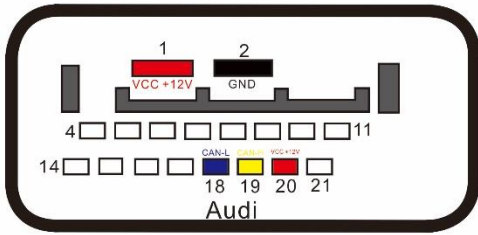

DL 501 (0B5)

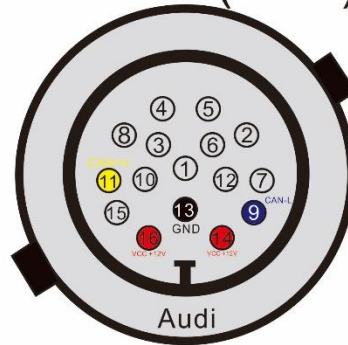

DC0/DC4 Gen2

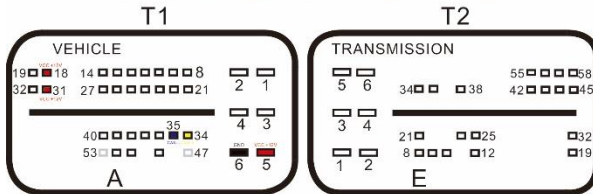

RENAULT

LuK-UDCT

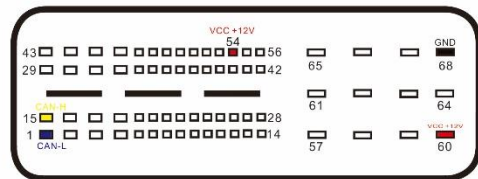

HONDA

KESV2: DQ200, DQ250, DQ500, Connection Diagram

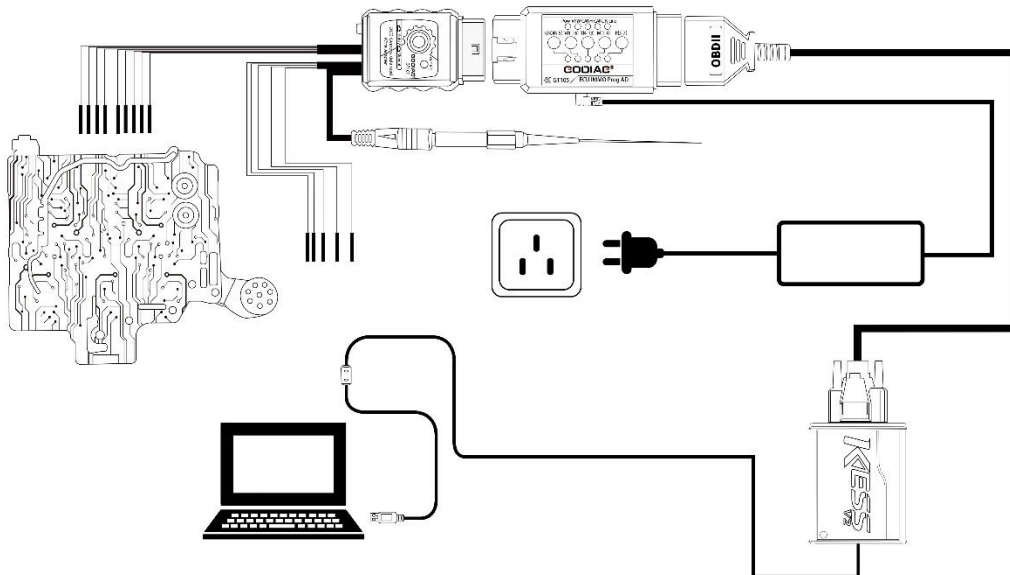

Steps:

1. Connect Godiag GT107 to gearbox ECU DQ250, DQ200, DQ500.
2. Connect the Godiag ECU IMMO Prog AD with the vehicle battery or 12v 3A power supply. (The Godiag ECU IMMO Prog AD's IMMO button must be up.)
3. Connect kessv2 device, and press down the GT107 switch and it will be in "Manual" ignition mode.
4. Press down the 120 ohm resistor switch.
5. Connect the computer and open the software to read and write data.

Work BOOT: use a direct connection to the connector of the control UNIT, the switching power supply is carried out either manually (recommended) or by using the scheme of automatic power control, GODIAG GT107 DSG gearbox data adapter (same PowerBox or converted from KESS). In case of manual control, the entrance to the boot mode may not happen on the first attempt.

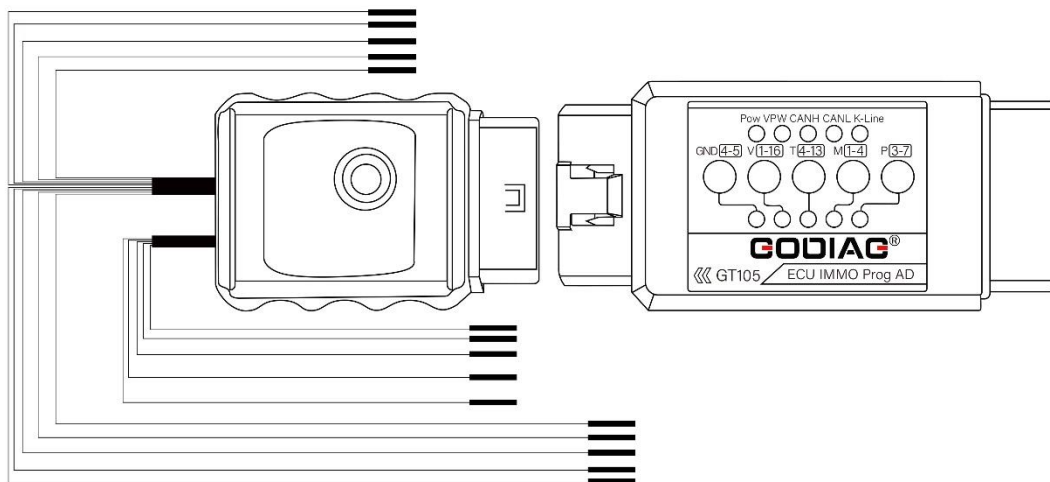

Read DQ500: only when connected directly!

NOTE: the power supply must be switched manually, while only the ignition must be switched on or off (pin 15), the second contact must be connected constantly.

DQ500(0BT,0BH)

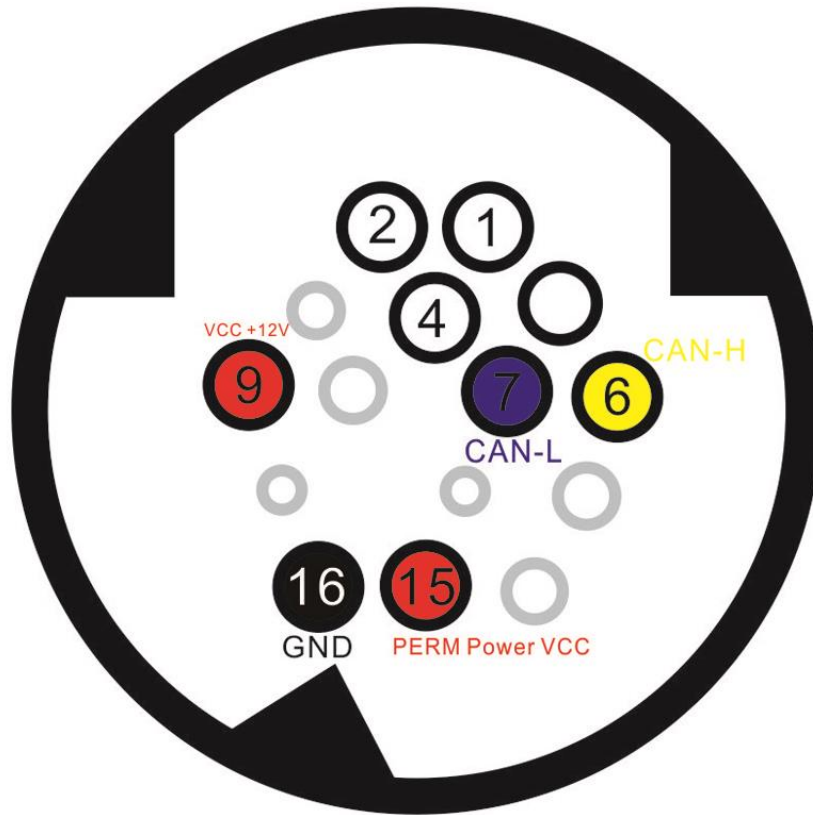

Operation in BSL with VL300 / V30: requires drilling a single hole in the minimum diameter cap in order to insert a probe into it. The probe is connected to the GODIAG GT107 DSG Gearbox Data Adapter BOOT 1k ohm GND line(included in the GT107 host). It is mandatory to connect to-line and it is highly recommended to use auto power to quickly “feel” the pin on the board. The photos below show the drilling location and the point on the board where the probe should go.

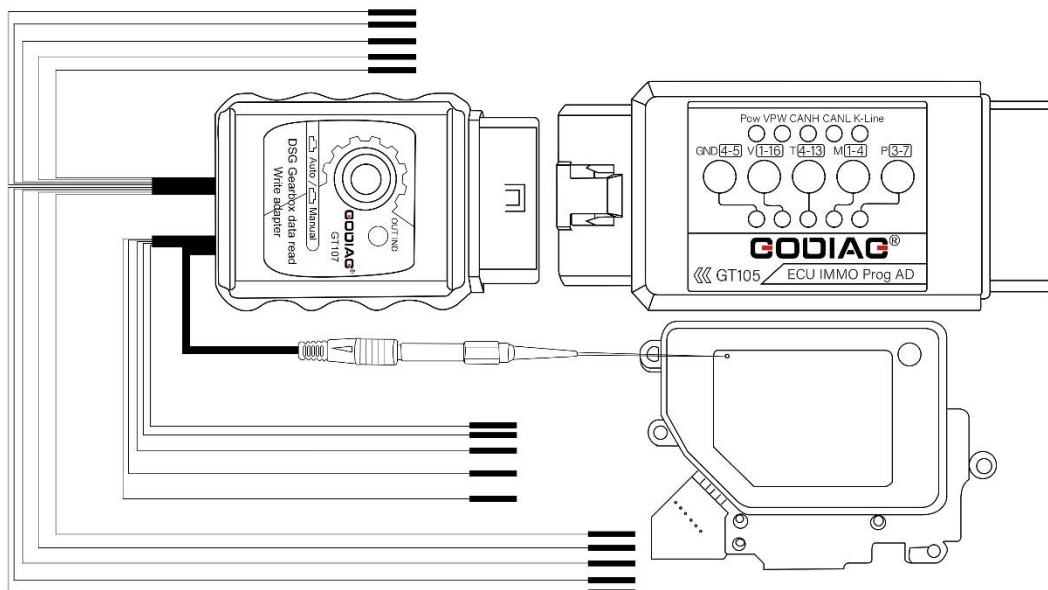

ECU Disassembly connection pin diagram

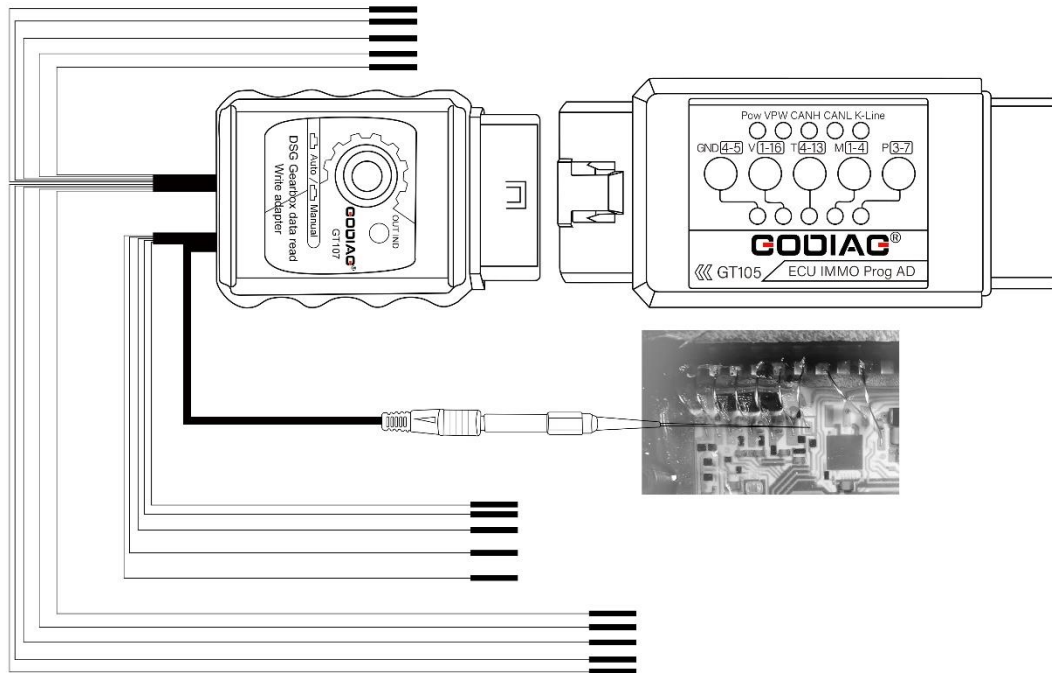

Package Includes:

- 1pc x Godiag ECU IMMO Prog AD
- 1pc x DSG Adapter
- 1pc x Power Cord with Battery Clip
- 1pc x Probe

GODIAG[®]

Shenzhen Sinoy Technology Co.,Ltd

All rights reserved

www.godiag.com

+86 18813687743

Sales@GoDiag.com



UK
CA

CE

FC



Thanks for reading!